

TC1910A, TC1910AX 9" Video Monitors

Service Manual

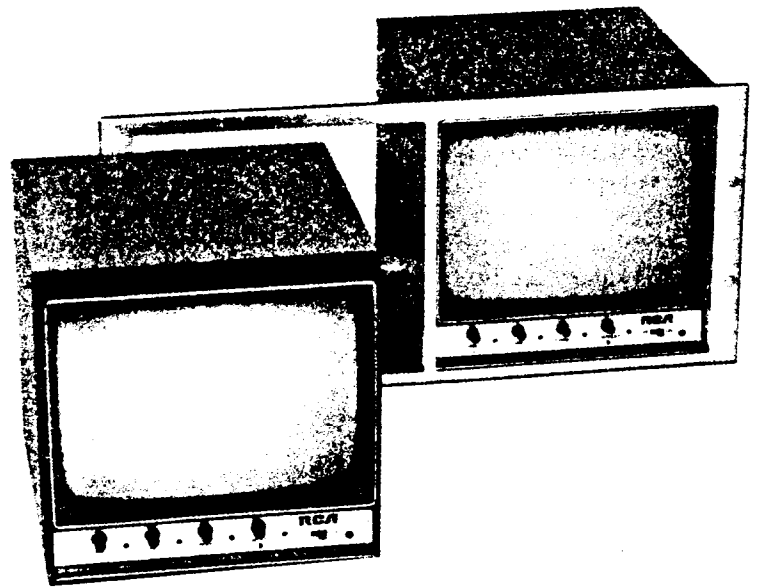

RCA Closed-Circuit
Video Equipment

Specifications

Resolution	Better than 700 lines
High Voltage	11 kV
Linearity	2% or better
DC Restoration	Front Panel Adjustable
Synchronization	Internally derived
Picture Tube	9 V, 9-inch (23 cm) diagonal. 90 degree deflection. Integral implosion protection
Input	0.5 to 2.0 Vp-p, sync-negative, composite video. Hi Z/75 ohm termination switch on rear panel.
Supply Voltage — AC or DC:	
DC	12 to 16 V DC
TC1910A	120 V (105 to 130 V), 60 Hz
TC1910AX	220 V (198 to 264 V), 50 Hz
Power:	
DC	15 watts at 12 V DC
TC1910A	30 watts at 120 VAC
TC1910AX	30 watts at 220 VAC
Size:	
Monitor	8.69" W x 8.56" H x 9.80" D (220 x 217 x 249 mm)
Rack	19" W x 8.75" H x 9.6" D (484 x 222 x 244 mm)
Weight:	
Monitor	12.4 lbs (5.64 kg)
Rack	7.3 lbs (3.34 kg)
Environment:	
Humidity	10 to 80% relative, non-condensing
Altitude	10,000 ft. (300 m)
Shipping Info:	
Size	14.4" x 13.1" x 13.0" (365 x 333 x 330 mm)
Weight	13.8 lbs (6.25 kg)
Accessories:	
DC Power Cord	TC1313

Specifications subject to change without notice.

Alignment

Initial Control Setup (Power Off).

Horizontal Hold	(R407) —	Mid range
Vertical Hold	(R301) —	Mid range
Brightness	(R109) —	Full CW
Contrast	(R107) —	Full CW
Vertical Height	(R303) —	Mid range
Vert Linearity	(R306) —	Mid range
DC Restoration	(R111) —	Full CW
Video Equalization	(R102) —	Full CCW
Termination (Rear Panel)	(S101) —	75 ohm

DC Level Checks

(See Figure 3 for Test Point locations).

Connect the line cord or DC input to the specified power source, move the Power Switch (S701) to On, and check the following voltages:

12 V Supply

(TP1 to Gnd), 11.9 ± 0.05 VDC

If out of range, adjust R703.

If unattainable, service the unit.

CRT G2 Voltage

(TP2 to Gnd), 130 ± 20.0 VDC

If out of range, adjust R421.

If reasonable brightness is unattainable check the CRT.

CRT Filament Voltage

(TP3 to Gnd), 11.5 ± 0.1 VDC

If out of range, service the unit.

CRT High Voltage, 11.5 kV (10.5 to 11.8 kV)

Use AC/DC Voltmeter and High Voltage Probe. Check from junction of CRT anode lead and main circuit board to ground. If out of range, service the unit.

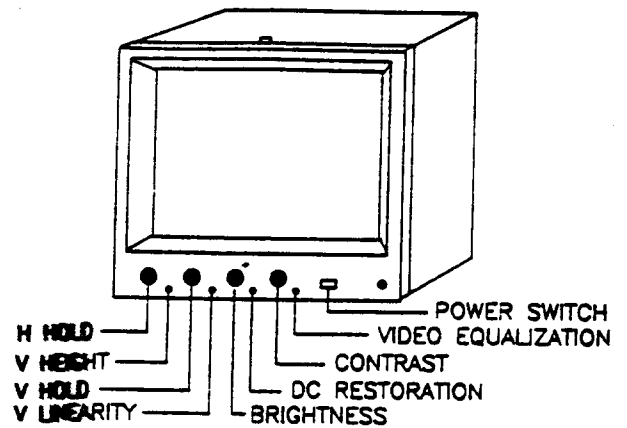

Figure 2 - Front Panel Controls

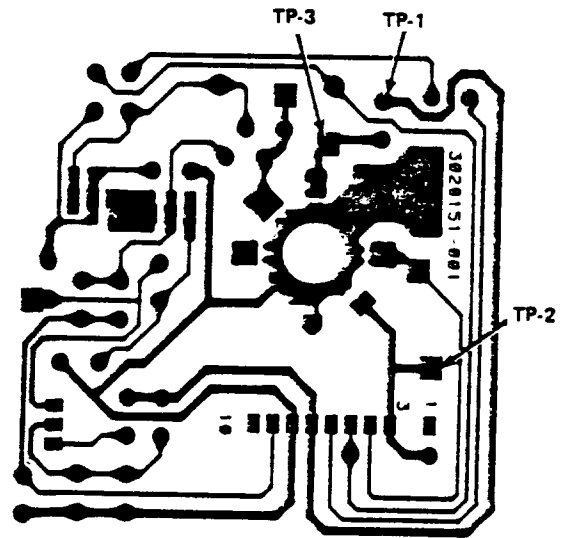

Figure 3 - Test Points

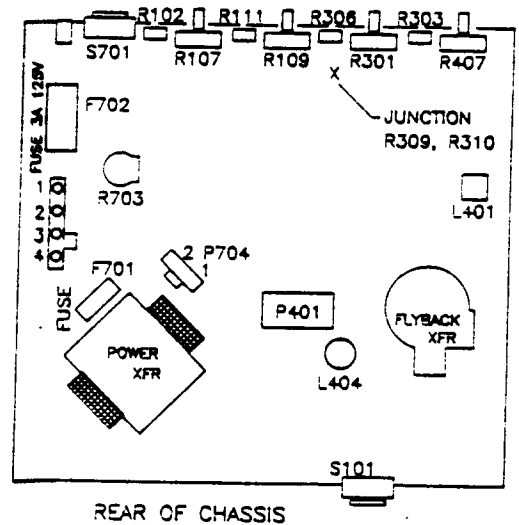

Figure 4 - Alignment Component Locations

Final Alignment

1. Using a good grade of 75 ohm video cable with BNC connectors, connect the video output of the camera to the Video Input of a known good monitor with its termination switch set at 75 ohms.
2. Turn on the camera and the known good monitor and, viewing the illuminated cross-hatch pattern, adjust the camera position until the pattern just overscans the monitor screen on all four sides. Lock the camera and the pattern in this position. Adjust pattern illumination and camera controls, as required, to obtain a good, sharp, in-focus picture.
3. Remove the video connection from the known good monitor and connect it to Video In (J101) of the monitor to be tested.
4. Reaffirm that the monitor termination switch on the rear panel is set to 75 ohms.
5. Turn on the camera and monitor, and with the camera viewing the crosshatch pattern, adjust the camera output to 1.0 Vp-p composite video.
A stable crosshatch pattern should appear on the monitor screen. If not:
 - a. Adjust Vertical Hold (R301) to obtain vertical picture locking. If unattainable, service the unit.
 - b. Adjust Horizontal Hold (R407) to obtain horizontal picture locking. If unattainable, first try resetting R407 to Mid range and, with the H-Freq Adjusting tool, adjusting the Horizontal Oscillator Coil (L401) until a stable picture is obtained. If still unattainable, service the unit.
6. Check Horizontal Hold (R407) for loss (or slight tearing) of horizontal sync at both ends of its range. If not present, readjust the Horizontal Oscillator Coil (L401) and repeat the check. If unattainable, service the unit.
7. Reset Horizontal Hold (R407) for the most stable picture.

8. Check Vertical Hold (R301) for loss of sync at both ends of its rotation. If unattainable, service the unit.

Reset Vertical Hold (R301) for the most stable picture.

9. Using the 3/16" blade screwdriver, adjust the Width Control (L404) until the left and right sides of the picture are slightly overscanned. Re-adjust the Yoke Centering Rings, if required, to keep the picture centered.
10. Adjust Vertical Linearity (R306), Vertical Height (R303) and the Yoke Centering Rings until the top and bottom of the picture are each slightly overscanned and the crosshatch pattern is uniform from top to bottom.

Note: The vertical sweep waveform can be observed at the junction of R309 R310 (See Waveform 6). Adjustment of Vertical Linearity will make the waveform concave, straight, or convex.

11. Replace the cross-hatch pattern with the EIA Resolution Chart 1956 and repeat steps 1, 2, and 3.
12. If necessary, adjust the appropriate yoke magnets to obtain round corner circles.
13. Adjust Contrast (R107) and Brightness (R109) for sharpest resolution while maintaining grey scale.

700 TV Line resolution should be clearly visible. If not, service the unit.

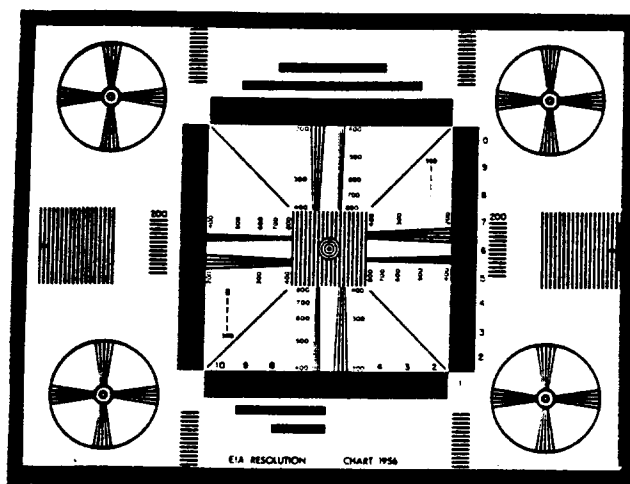

Figure 5 - Resolution Chart

Troubleshooting

DC Voltage Levels - Transistors

Part No.	Config.	Emitter	Base	Collector
Q101	B	4.77	5.43	11.68
Q102	B	54.70	53.80	19.60
Q501	B	12.72	13.35	18.38
Q502	B	18.37	18.98	43.90
Q503	B	12.65	11.98	12.11
Q201	B	0.88	1.48	5.69
Q202	B	8.29	5.69	11.59
Q203	B	11.69	11.59	1.94
Q401	B	0.47	0.43	10.03
Q402	B	0.01	0.33	10.24
Q403	A	0.15	-0.15	11.95
Q404	B	-83.80	-83.80	-10.30
Q701	A	18.12	17.47	12.03
Q702	B	17.22	16.62	0.35
Q703	B	5.89	6.44	16.62

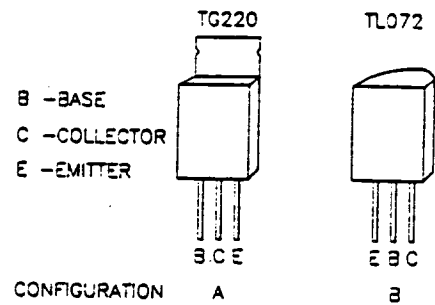

Figure 6 - Transistor Configurations

DC Voltage Levels - IC U301

Pin No.	Volts	Pin No.	Volts
1	3.87	7	6.47
2	11.26	8	0.35
3	0.43	9	2.69
4	5.86	10	2.13
5	10.90	11	0.68
6	6.38	12	2.96

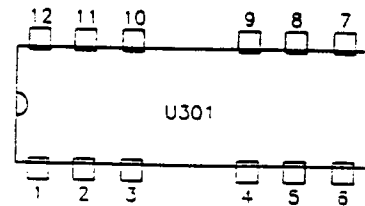

Figure 7 - IC U301 Pin Layouts

Connectors

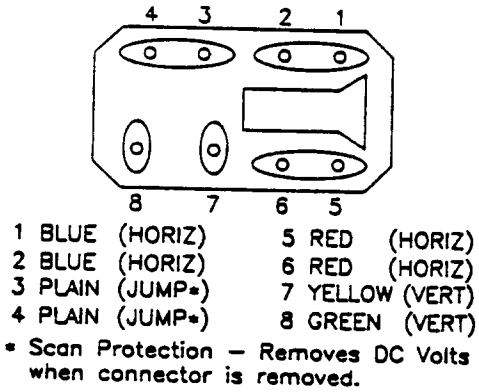

Figure 9 - Yoke to PC Board Connector

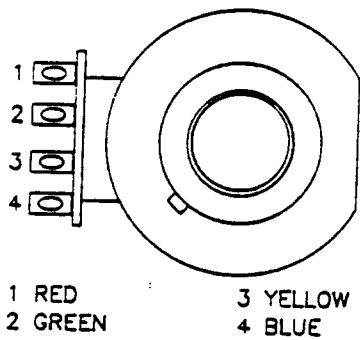

Figure 10 - Yoke Connections

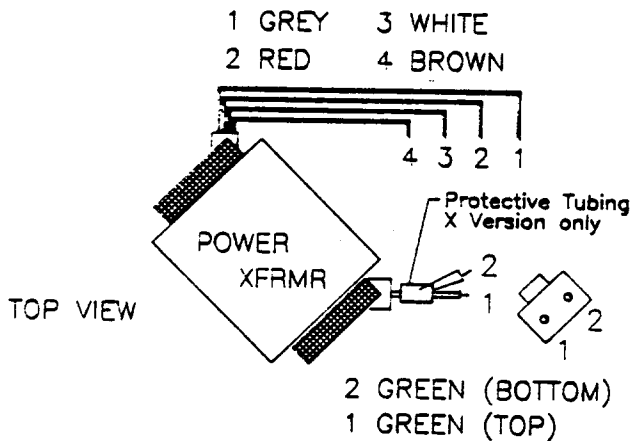

Figure 11 - Transformer Connections

PC Board Removal

1. If CRT has not been removed, discharge CTR to ground, unplug CRT anode contact from button on side of CRT and carefully remove yoke plug from PC Board socket.
2. Remove the two PC Board Mount Screws at the rear of the chassis.
3. Remove the Main PC Board Braid Ground Lead plug from the PC Board.
4. Carefully slide the Main PC Board back until free.

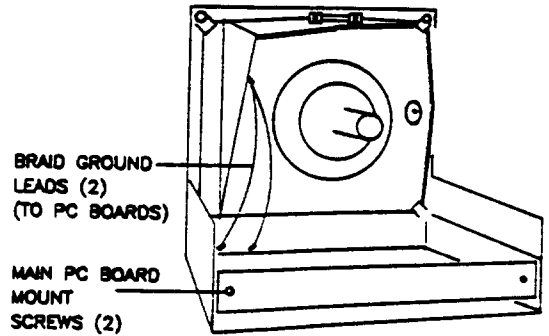

Figure 12 - PC Board Removal

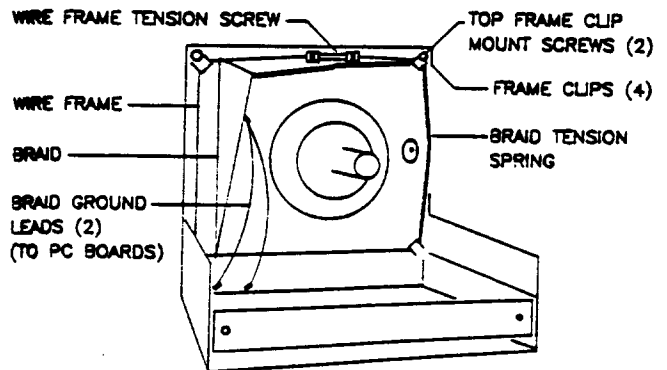

Figure 13 - CRT Removal

Replacement Parts

Symbol	Stock No	Drawing No	Description
			L TC1910A/AX MONITOR
	465405	3028148-0501	CIRCUIT - COMPLETE BRD. ASSM (120V)
	465406	3028148-0502	CIRCUIT - COMPLETE BRD. ASSM (240V)
C101	152267	2841274-0532	47UF 16V ELECTROLYTIC
C102	161205	2844807-0331	220UF 16V ELECTROLYTIC
C103	152267	2841274-0532	47UF 16V ELECTROLYTIC
C104	146833	2841251-093A	33PF 5% 50V CERAMIC NPO
C105	161205	2844807-0331	220UF 16V ELECTROLYTIC
C201	146256	2841274-0142	10UF 25V ELECTROLYTIC
C202	141868	2841273-0162	1UF 20% 50V ELECTROLYTIC
C203	152246	2844805-0161	1UF 50V ELECTROLYTIC
C204	151501	2871332-0004	10UF 16V ELECTROLYTIC
C301	433440	3027808-0029	220000PF 5% 50V CERAMIC
C302	159640	2872860-0225	.1UF 5% 50V FILM
C303	159640	2872860-0225	.1UF 5% 50V FILM
C304	146833	2841251-093A	33PF 5% 50V CERAMIC NPO
C305	146256	2841274-0142	10UF 25V ELECTROLYTIC
C306	159640	2872860-0225	.1UF 5% 50V FILM
C307	127098	2844808-0131	1000UF 16V ELECTROLYTIC
C308	161205	2844807-0331	220UF 16V ELECTROLYTIC
C309	159640	2872860-0225	.1UF 5% 50V FILM
C310	161205	2844807-0331	220UF 16V ELECTROLYTIC
C311	161380	2872860-0213	.01UF 5% 50V FILM
C312	161380	2872860-0213	.01UF 5% 50V FILM
C313	159640	2872860-0225	.1UF 5% 50V FILM
C401	161380	2872860-0213	.01UF 5% 50V FILM
C402	161205	2844807-0331	220UF 16V ELECTROLYTIC
C404	151509	2872860-0115	.015UF 5% 50V FILM
C405	160136	2872860-0111	.0068UF 10% 50V FILM
C406	174178	2872860-0119	.033UF 10% 50V FILM
C407	151509	2872860-0115	.015UF 5% 50V FILM
C408	146218	2844808-0141	1000UF 25V ELECTROLYTIC
C409	465833	3028021-0100	10UF 25V ELECTROLYTIC (NONPOLAR)
C410	465407	3027502-0416	.018UF 10% 400V FILM
C411	453141	1449706-0028	.022UF 10% 400V FILM
C412	453141	1449706-0028	.022UF 10% 400V FILM
C413	159640	2872860-0225	.1UF 5% 50V FILM
C414	158420	3027623-0901	1UF 20% 160V ELECTROLYTIC
C415	149811	2875004-0070	4700PF 10% 500V CERAMIC
C416	105310	2875004-032R	390PF 10% 500V CERAMIC
C417	153314	1490001-0033	3.3UF +100% -10% 160V ELECTROLYTIC
C418	173893	2872860-0217	.022UF 5% 50V FILM
C419	173893	2872860-0217	.022UF 5% 50V FILM
C420	153314	1490001-0033	3.3UF +100% -10% 160V ELECTROLYTIC
C421	149811	2875004-0070	4700PF 10% 500V CERAMIC
C701	149811	2875004-0070	4700PF 10% 500V CERAMIC
C702	149811	2875004-0070	4700PF 10% 500V CERAMIC
C703	149811	2875004-0070	4700PF 10% 500V CERAMIC

Symbol	Stock No	Drawing No	Description
C704	149811	2875004-0070	4700PF 10% 500V CERAMIC
C705	157466	1490001-0036	3300UF 25V ELECTROLYTIC
C706	442318	2872860-0105	.0022UF 5% 50V FILM
C707	455350	2872860-0201	.001UF 5% 50V FILM
D201	429870	3027815-0009	DIODE - TYPE 1N4448
D202	429870	3027815-0009	DIODE - TYPE 1N4448
D203	429870	3027815-0009	DIODE - TYPE 1N4448
D301	426115	3029357-0001	DIODE - TYPE 1N4001
D302	426115	3029357-0001	DIODE - TYPE 1N4001
D401	429870	3027815-0009	DIODE - TYPE 1N4448
D402	429870	3027815-0009	DIODE - TYPE 1N4448
D403	449937	3028080-0001	DIODE - TYPE MR504
D404	463884	3027815-0013	DIODE - TYPE 1N459A
D405	463884	3027815-0013	DIODE - TYPE 1N459A
D406	463884	3027815-0013	DIODE - TYPE 1N459A
D407	464011	3027182-0008	DIODE - TYPE RGP10K
D408	463884	3027815-0013	DIODE - TYPE 1N459A
D701	465408	3028061-0002	DIODE - TYPE BRIDGE
E701	465420	3027647-0502	DIODE - LED ASSEM (GREEN)
F701	427390	990157-0106	FUSE - 1/2 AMP 250V
F702	144187	3028133-0004	FUSE - 3A 250V SLO-BLOW
F701	441453	3028085-0011	FUSE - .315A 250V SLO-BLOW TC1910AX
F702	158939	3028134-0006	FUSE - 3.15A 250V SLO-BLOW TC1910AX
J701	465419	3028051-0001	JACK - DC POWER
L401	465413	3028015-0001	INDUCTOR - VARIABLE 16MH +/- 1.6MH
L403	465414	3028017-0001	COIL - LINEARITY 3-7UH
L404	465415	3028018-0001	COIL - HOR.WIDTH 8+/-3UH
R101	421517	2874082-0370	75 OHM 1% 1/4W FILM
R102	461292	3023270-0009	5000 OHM LINEAR VARIABLE
R103	144868	2874082-0429	2200 OHM 2% 1/4W FILM
R104	144868	2874082-0429	2200 OHM 2% 1/4W FILM
R105	442203	2874082-0375	120 OHM 1% 1/4W FILM
R106	442213	2874082-0389	470 OHM 1% 1/4W FILM
R107	465409	3028013-0501	500 OHM LINEAR VARIABLE
R108	432574	990401-0434	22100 OHM 1% 1/4W FILM
R109	464038	3028013-0104	100000 OHM LINEAR VAR.
R110	439884	990401-0530	200000 OHM 1% 1/4W FILM
R111	463914	3023270-0020	500000 OHM LINEAR VARIABLE
R112	144868	2874082-0429	2200 OHM 2% 1/4W FILM
R113	451789	2874082-0461	470000 OHM 2% 1/4W FILM
R114	442189	2874082-0357	22 OHM 1% 1/4W FILM
R115	442189	2874082-0357	22 OHM 1% 1/4W FILM
R116	432505	990401-0512	130000 OHM 1% 1/4W FILM
R117	436141	990401-0501	100000 OHM 1% 1/4W FILM
R201	829310	2874082-0421	10000 OHM 2% 1/4W FILM FP
R202	829310	2874082-0421	10000 OHM 2% 1/4W FILM FP

Symbol	Stock No	Drawing No	Description
R702	442215	2874082-0391	560 OHM 1% 1/4W FILM
R703	463892	3023041-0005	500 OHM LINEAR VARIABLE
R704	151315	2874082-0395	820 OHM 1% 1/4W FILM
R705	442215	2874082-0391	560 OHM 1% 1/4W FILM
R706	442203	2874082-0375	120 OHM 1% 1/4W FILM
R707	442203	2874082-0375	120 OHM 1% 1/4W FILM
R708	421517	2874082-0370	75 OHM 1% 1/4W FILM
R709	442235	2874082-0417	6800 OHM 1% 1/4W FILM
R711	442223	2874082-0405	2200 OHM 1% 1/4W FILM
Q101	143794	1417306-0012	TRANSISTOR - TYPE SPECIAL
Q102	440123	3028072-0001	TRANSISTOR - TYPE MPS-A92
Q201	143794	1417306-0012	TRANSISTOR - TYPE SPECIAL
Q202	143794	1417306-0012	TRANSISTOR - TYPE SPECIAL
Q203	145410	1417330-0015	TRANSISTOR - TYPE SPECIAL
Q401	143794	1417306-0012	TRANSISTOR - TYPE SPECIAL
Q402	463888	3027652-0001	TRANSISTOR - TYPE 2N6718
Q404	464111	3028073-0001	TRANSISTOR - TYPE 2N5551 SPECIAL
Q702	145410	1417330-0015	TRANSISTOR - TYPE SPECIAL
Q703	143794	1417306-0012	TRANSISTOR - TYPE SPECIAL
			TRANSISTOR ASSEMBLY
Q403	465436	3028044-0001	TRANSISTOR - TYPE 2N6704
Q701	465571	3028043-0001	TRANSISTOR - TYPE 2N6109
	134753	990445-0001	WASHER - MICA (PT OF TRANS ASSM)
	464058	3023326-0413	SCREW - 4-40X1/4 (PT OF TRANS ASSM)
S101	465417	3028028-0002	SWITCH - SPDT
S701	465418	3028028-0001	SWITCH - DPDT
T401	465416	3028019-0001	TRANSFORMER - HOR. DRIVE
T402	464108	3028020-0001	TRANSFORMER - FLYBACK
T701	464112	3028135-0501	TRANSFORMER - POWER W/ASSEM
U301	464040	3028042-0001	IC - TYPE TDA1170S
Z701	249956	3023741-0211	DIODE - TYPE 1N5234B
	465421	3028076-0001	SPACER - PLASTIC
			SOCKET PCB
C501	146833	2841251-093A	33PF 5% 50V CERAMIC NPO
C502	143871	2841252-063A	100PF 50V CERAMIC NPO
C503	442318	2872860-0105	.0022UF 5% 50V FILM
C504	174178	2872860-0119	.033UF 10% 50V FILM
C506	146256	2841274-0142	10UF 25V ELECTROLYTIC
D501	463884	3027815-0013	DIODE - TYPE 1N459A

TC1910A/TC1910AX
S3020150-003
9/11/85

A

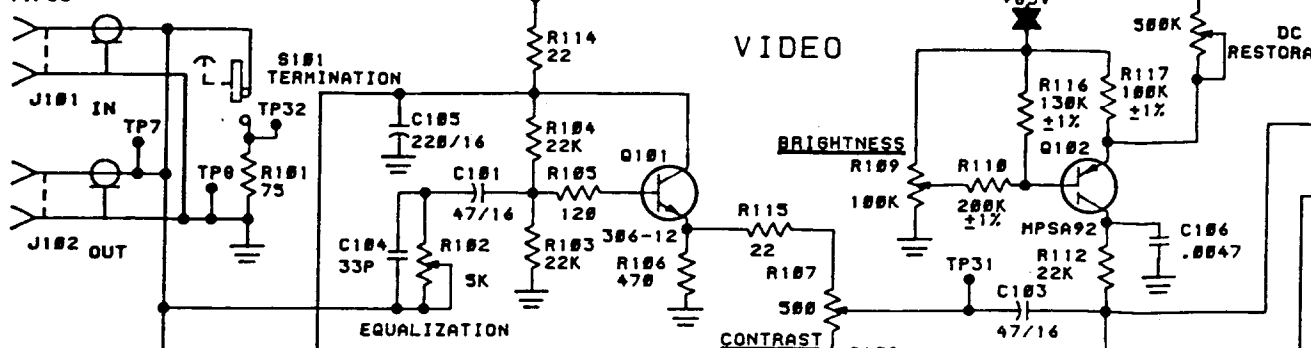

B

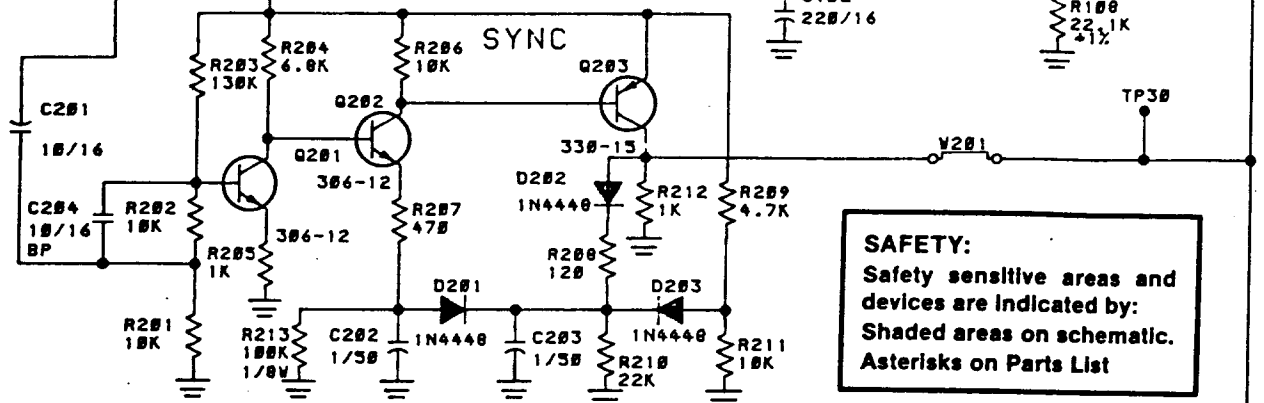

C

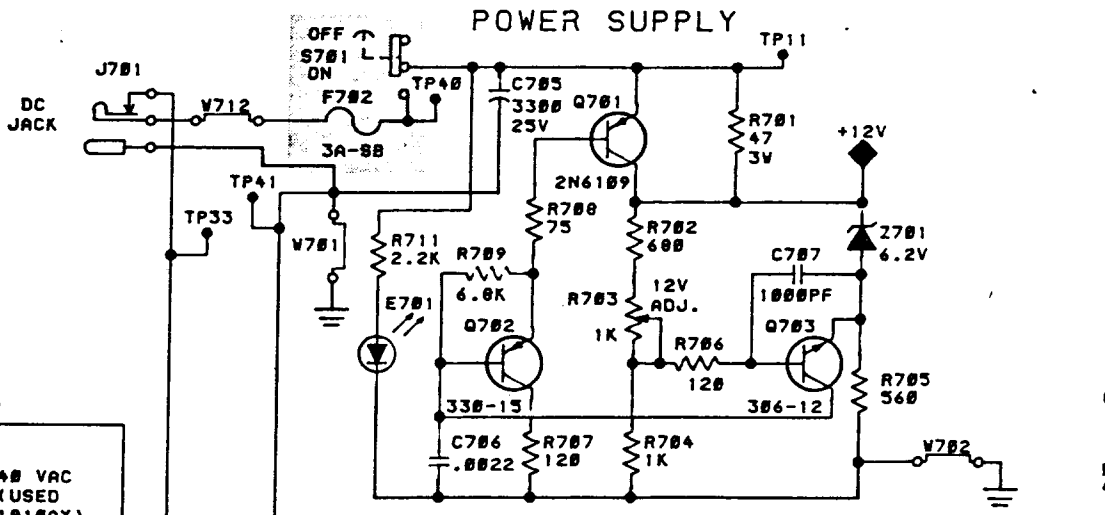

D

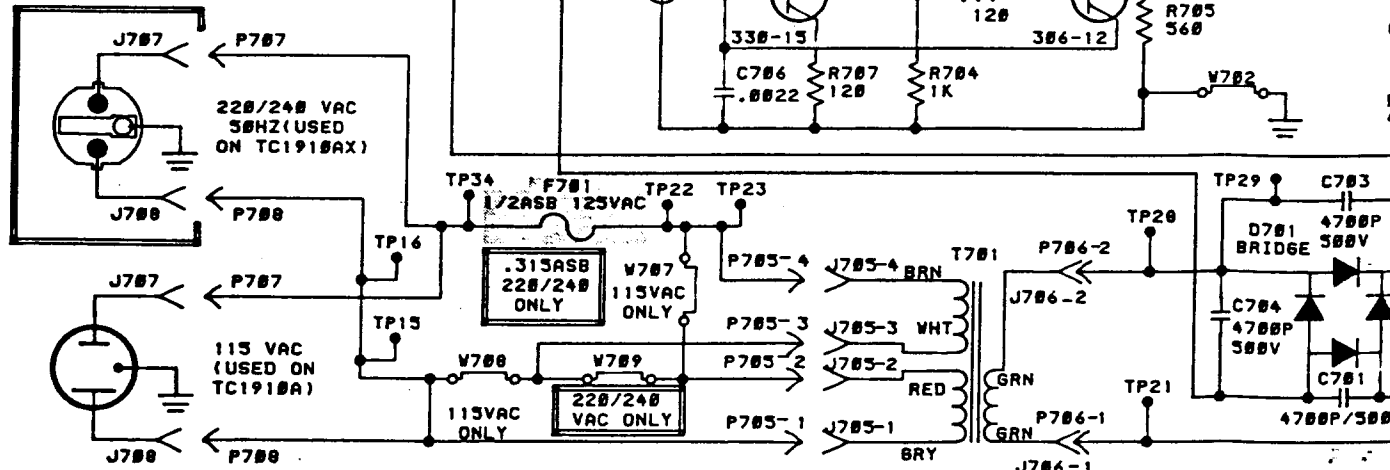

E

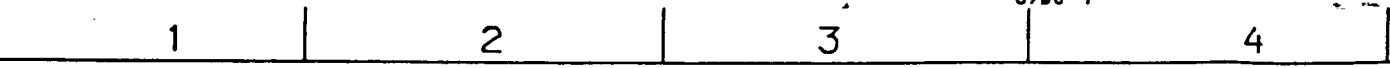

SAFETY:
Safety sensitive areas and devices are indicated by:
Shaded areas on schematic.
Asterisks on Parts List

C
.6
R4
47

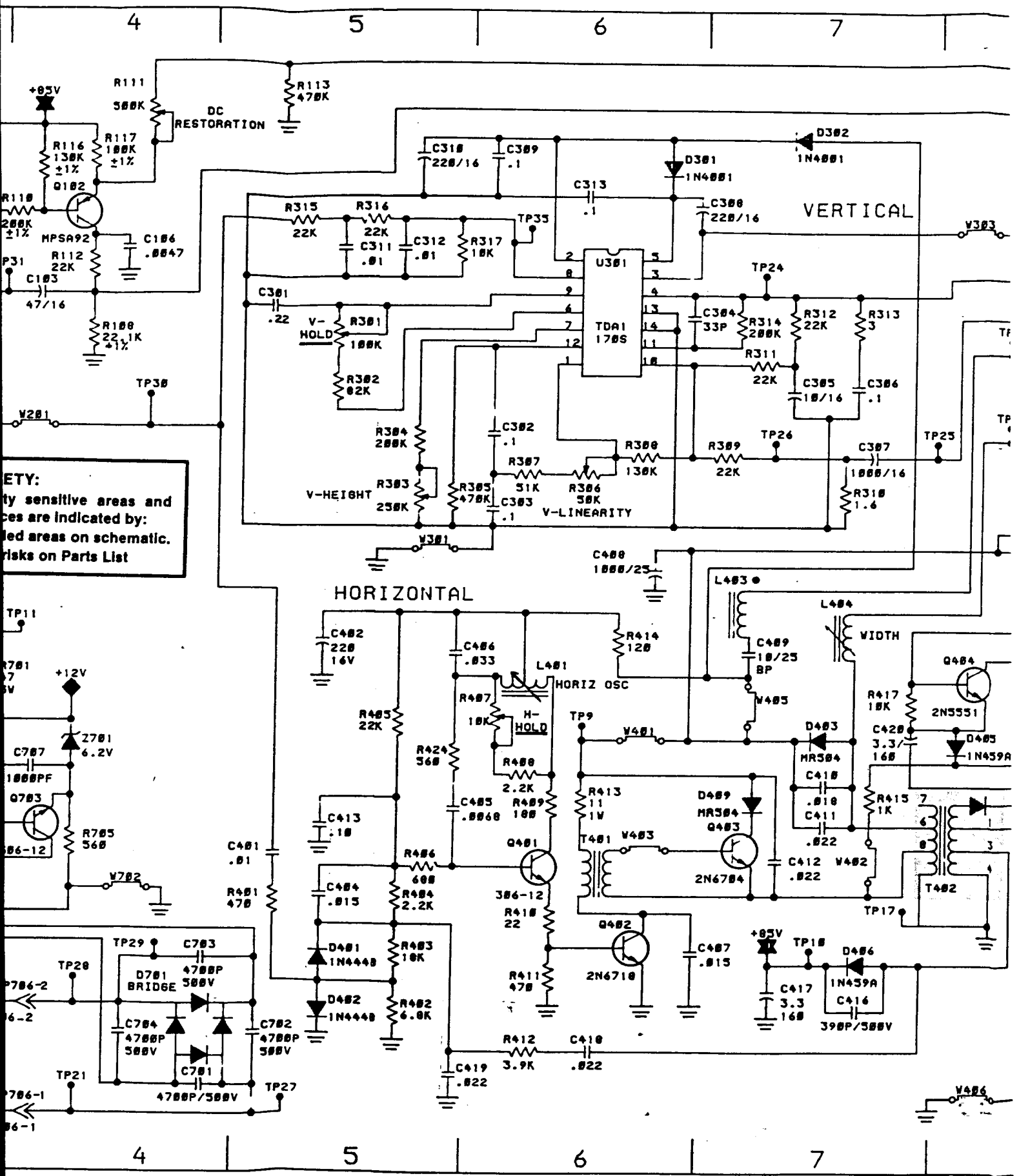

CAUTION:
 Sensitive areas and
 critical areas are indicated by:
 Shaded areas on schematic.
 Critical risks on Parts List

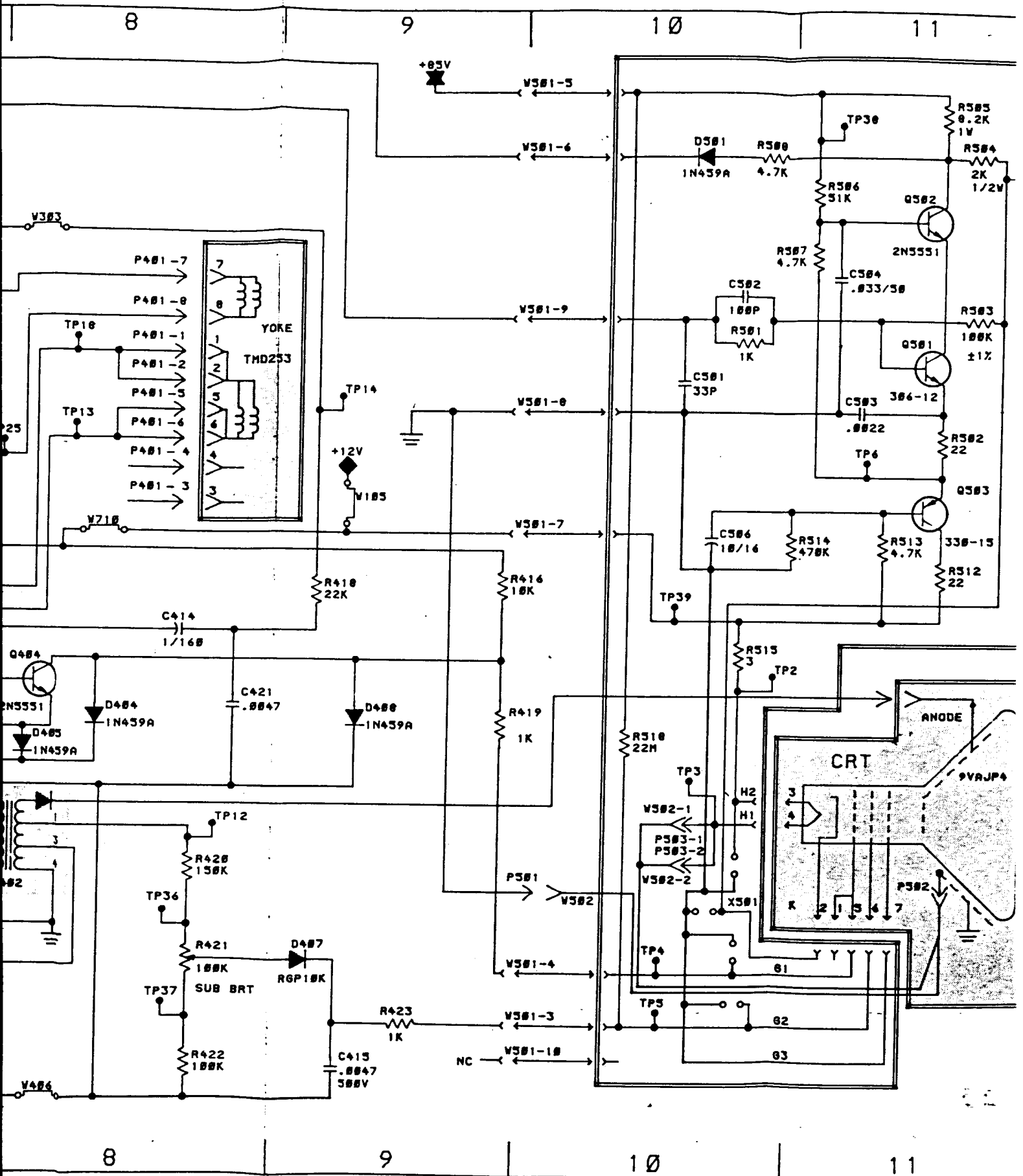

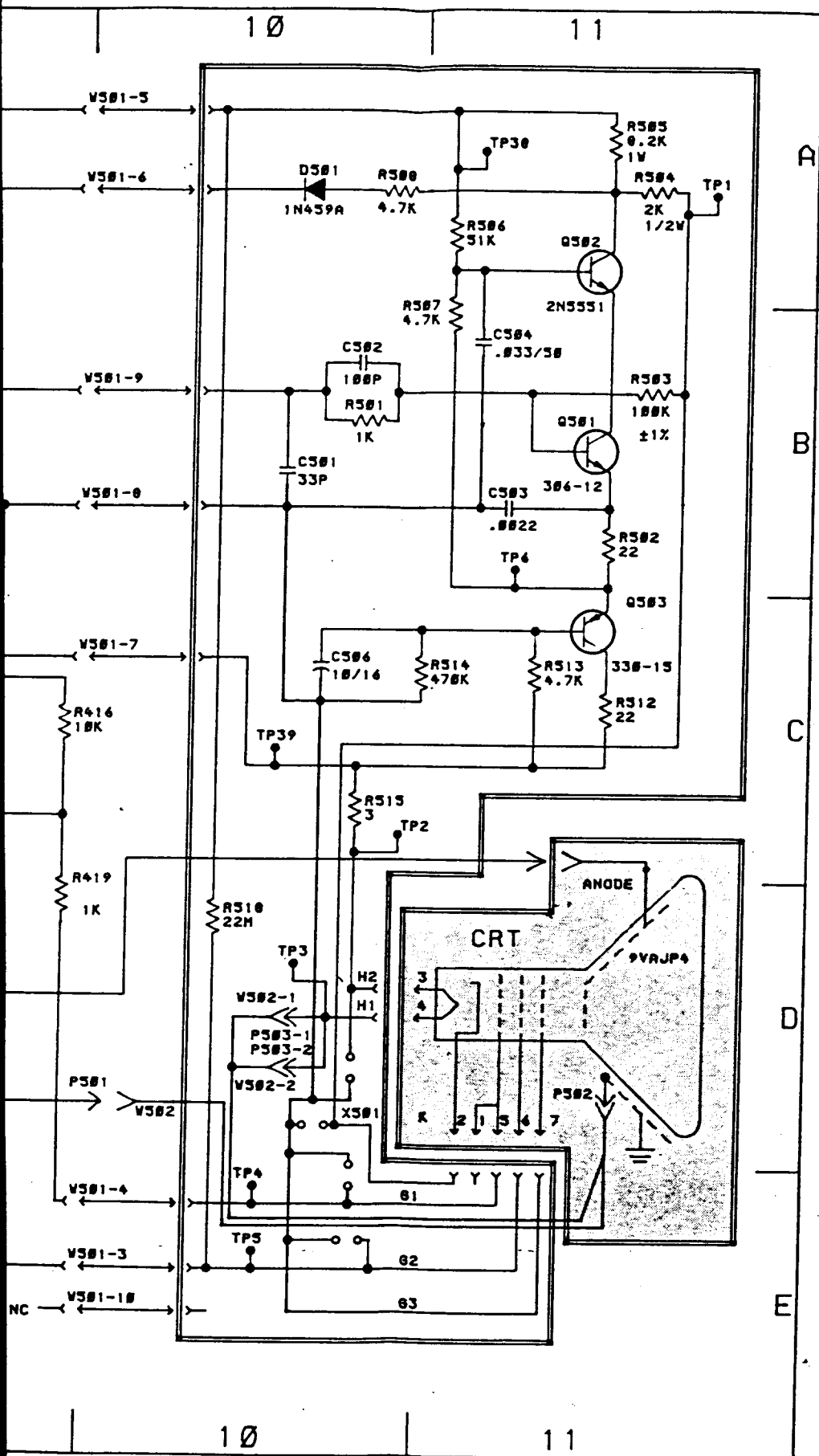

TC1910A/TC1910AX
S3028150-003
9/11/65

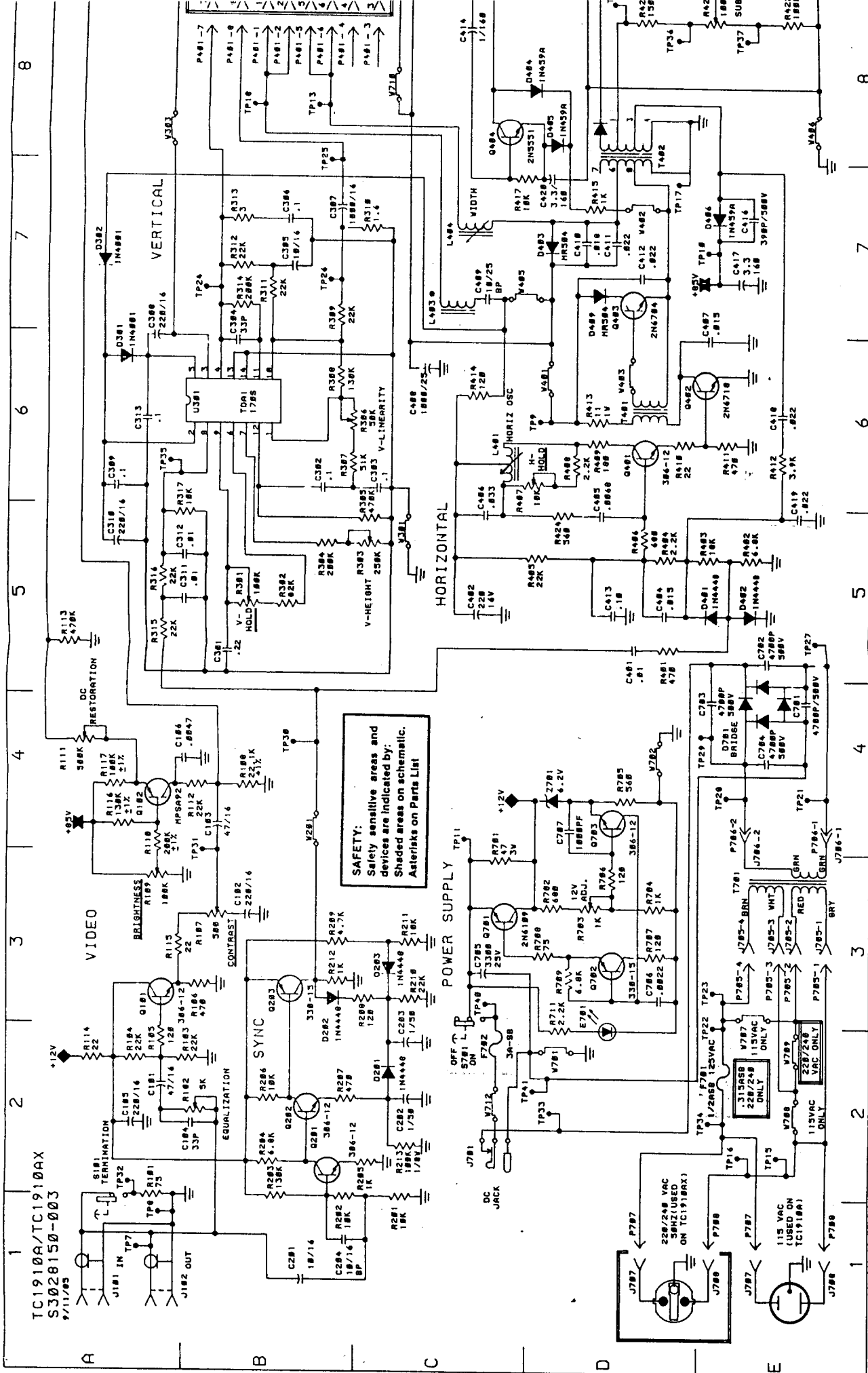

SAFETY:
Safety sensitive areas and
devices are indicated by:
Shaded areas on schematic.
Asterisks on Parts List.

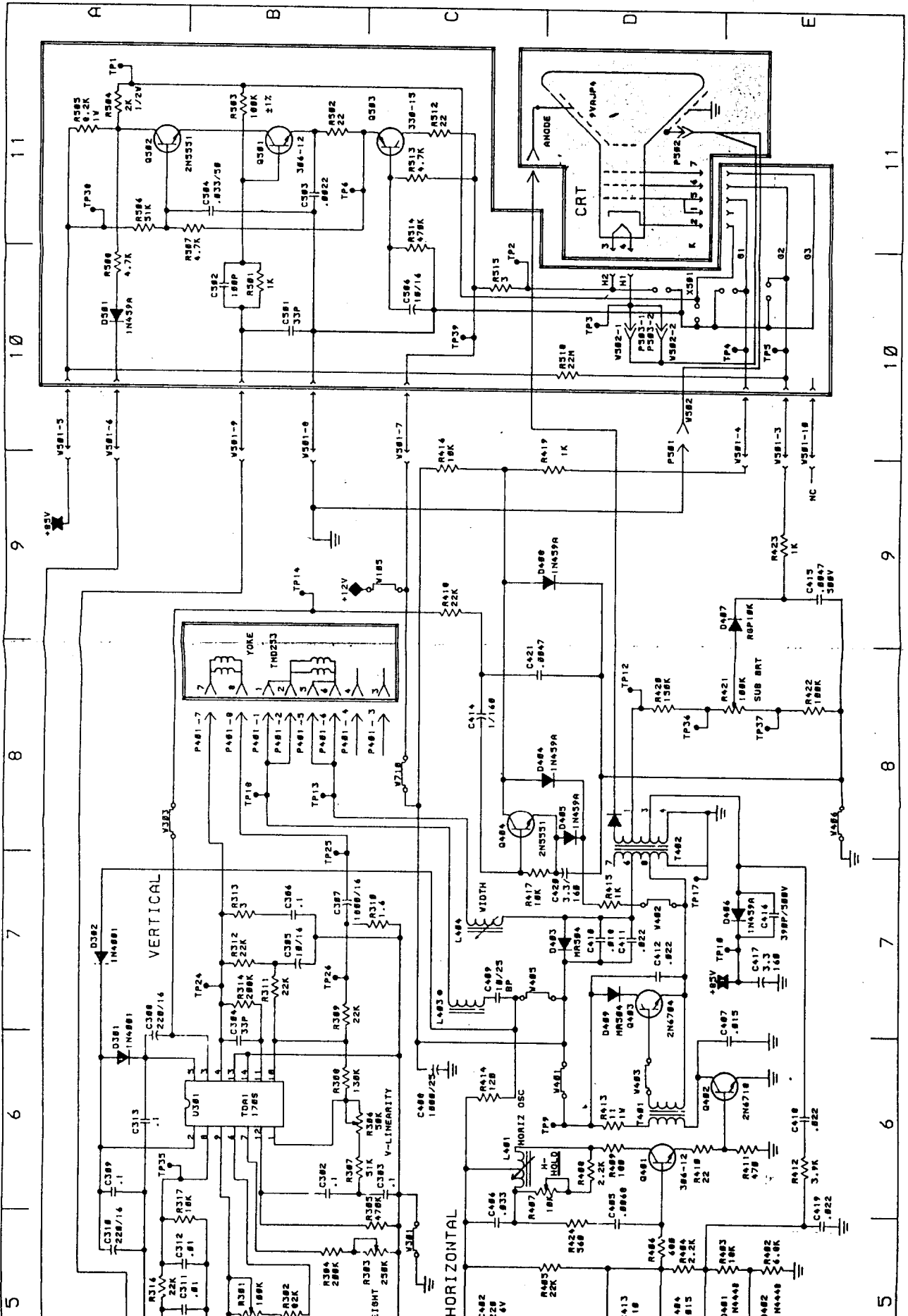

3

4

5

6

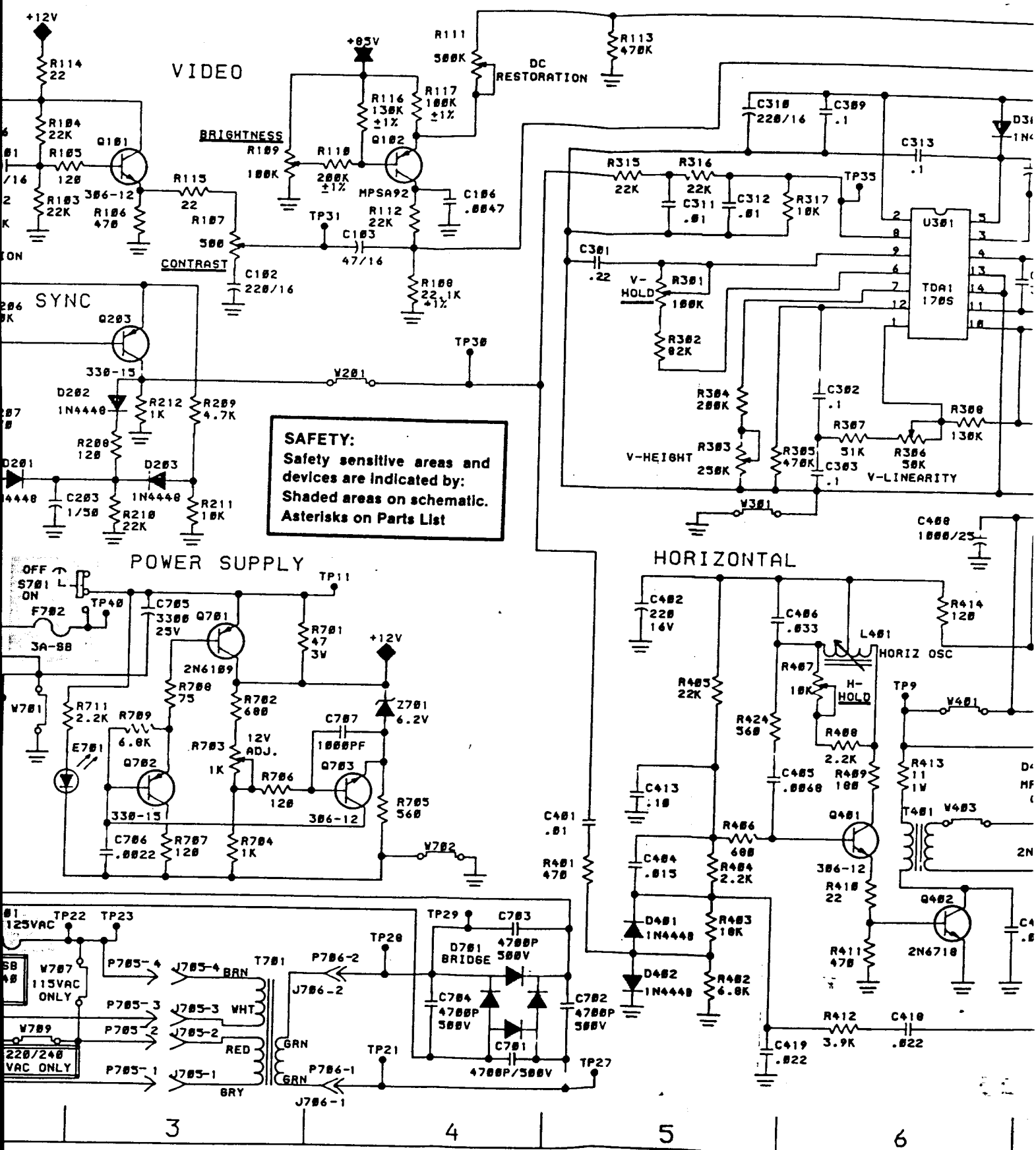

3

4

5

6

5

6

7

8

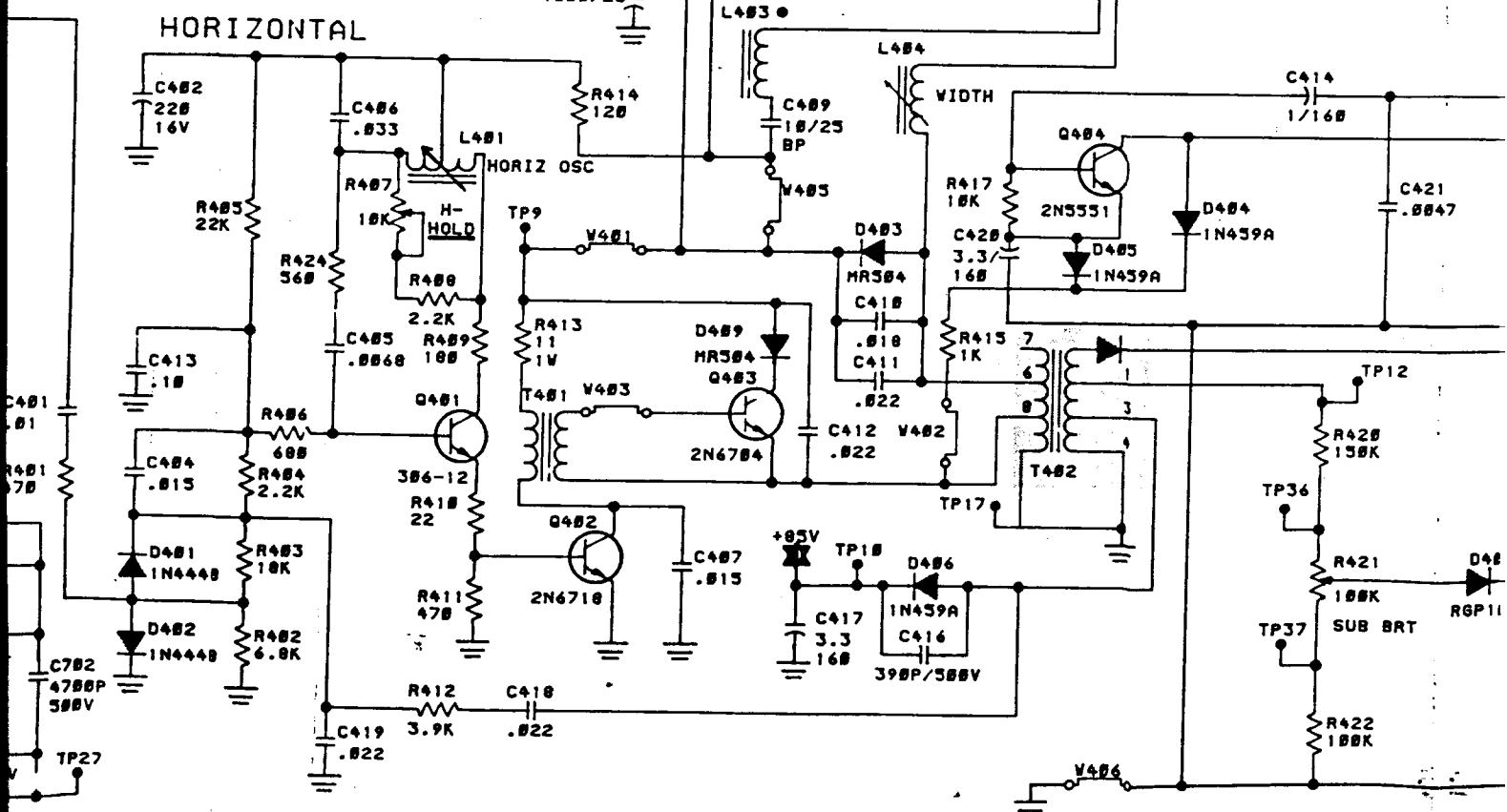
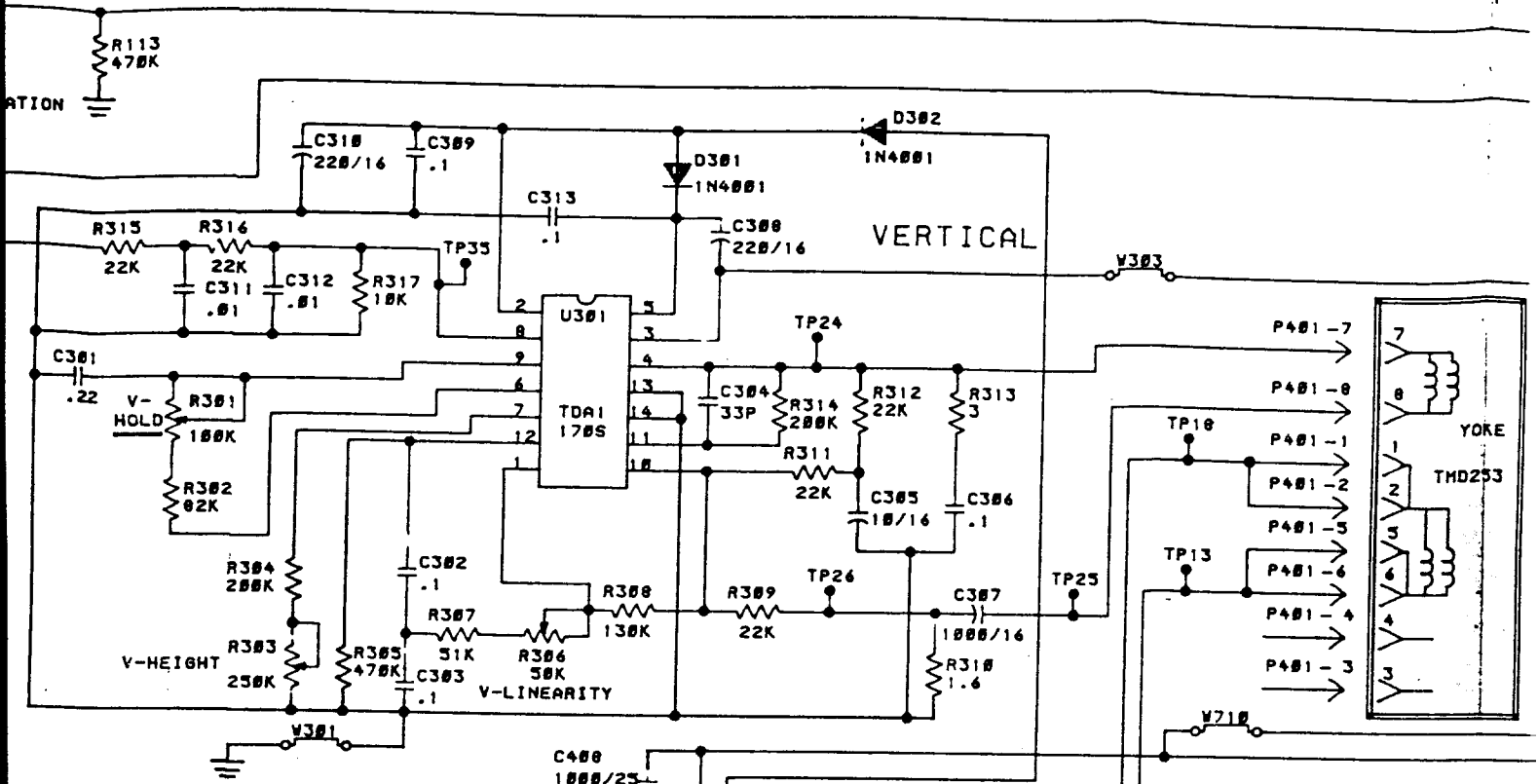

5

6

7

8

